

TABLE-A		TABLE-B		TABLE-C	
1 #4 X 2'-5" @24" N-S (a)	1 #4 X 5'-1" @24" N-S	1 #4 X 6'-2" @24" N-S (a)	1 #4 X 7'-5" @24" N-S	1 #4 X 2'-5" @24" N-S (a)	1 #4 X 5'-2" @24" N-S
1 #4 X 5'-1" @24" N-S	1 #4 X 7'-9" @24" N-S	1 #4 X 7'-5" @24" N-S	1 #4 X 9'-0" @24" N-S	1 #4 X 5'-2" @24" N-S	1 #4 X 8'-4" @24" N-S
1 #4 X 7'-9" @24" N-S	1 #4 X 7'-4" @24" N-S (b)	1 #4 X 7'-5" @24" N-S	1 #4 X 13'-5" @24" N-S	1 #4 X 8'-4" @24" N-S	1 #4 X 8'-10" @24" N-S
		1 #4 X 16'-3" @24" N-S (b)	1 #4 X 16'-3" @24" N-S (b)	1 #4 X 8'-10" @24" N-S	1 #4 X 11'-0" @24" N-S (b)

FOR CONTINUATION REFER PART B SLAB DWG NO: R76 TO R78

MATCH LINE A-A (PART A)
MATCH LINE A-A (PART B)

SIZE	4000 PSI	
	TOP	OTHERS
#3	24"	19"
#4	32"	25"
#5	40"	31"
#6	48"	37"
#7	70"	54"
#8	80"	62"
#9	91"	70"
#10	102"	79"
#11	113"	87"

ABBREVIATIONS	
STIRRUP	STIRR.
TOP & BOTTOM	T&B
TOP OF SLAB	T.O.S
NORTH-SOUTH	N-S
EAST-WEST	E-W

(BOTTOM BAR ARRANGEMENT)
PART A SECOND FLOOR SLAB LAYOUT
SCALE - 7/64"=1'-0"
REF: S2.0A

SAMPLE



(ADDITIONAL BAR ARRANGEMENT)
 PART A SECOND FLOOR SLAB LAYOUT
 SCALE - 7/64"=1'-0"
 REF: S2.0A

FOR CONTINUATION REFER PART B SLAB DWG NO: R76 TO R78

MATCH LINE A-A (PART A)
 MATCH LINE A-A (PART B)

SIZE	4000 PSI	
	TOP	OTHERS
#3	24"	19"
#4	32"	25"
#5	40"	31"
#6	48"	37"
#7	70"	54"
#8	80"	62"
#9	91"	70"
#10	102"	79"
#11	113"	87"

ABBREVIATIONS	
STIRRUP	STIRR.
TOP & BOTTOM	T&B
TOP OF SLAB	T.O.S
NORTH-SOUTH	N-S
EAST-WEST	E-W

SAMPLE

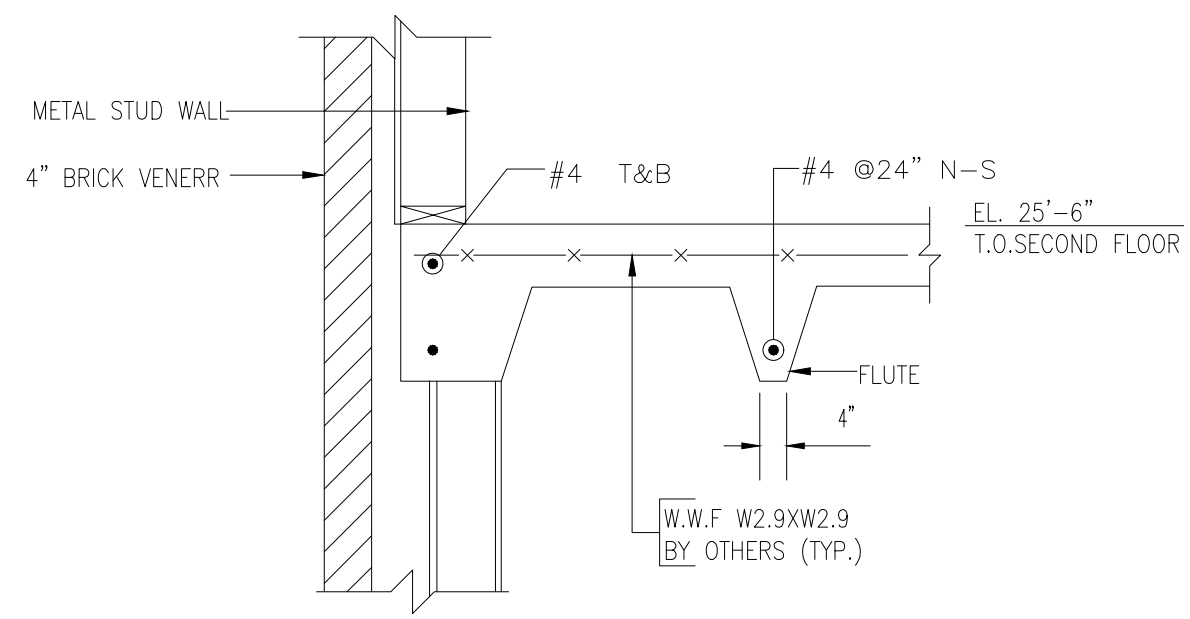

SECTION 1
SCALE - 3/4"=1'-0"
REF:1A/SD2.0

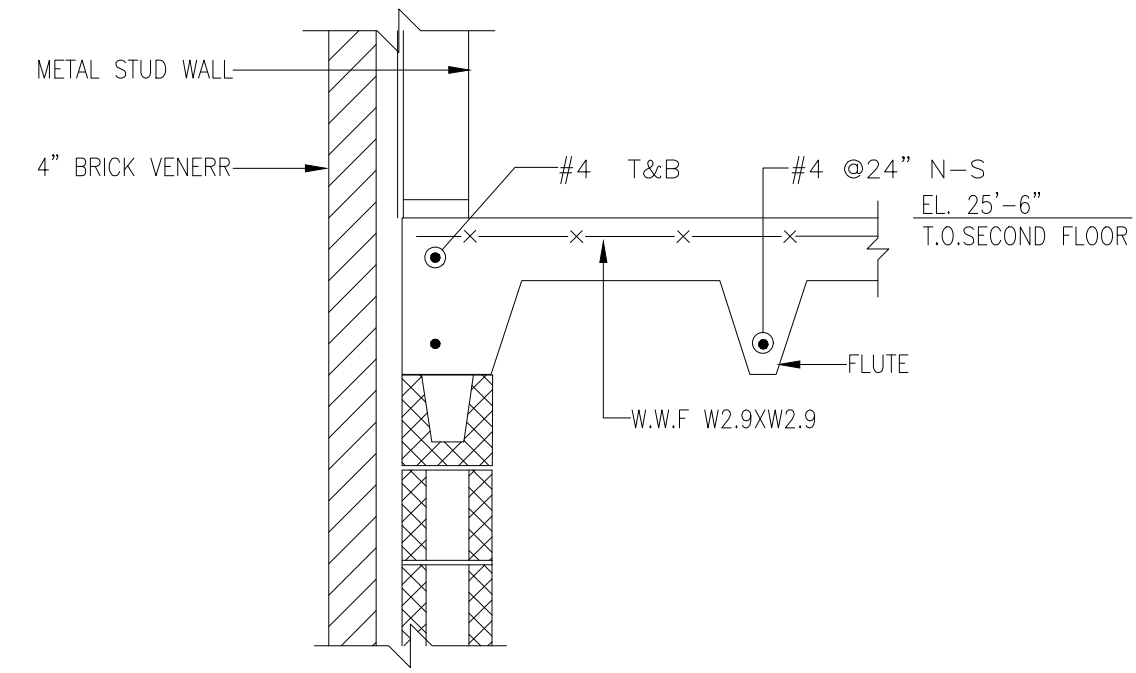

SECTION 2
SCALE - 3/4"=1'-0"
REF:8/SD2.0

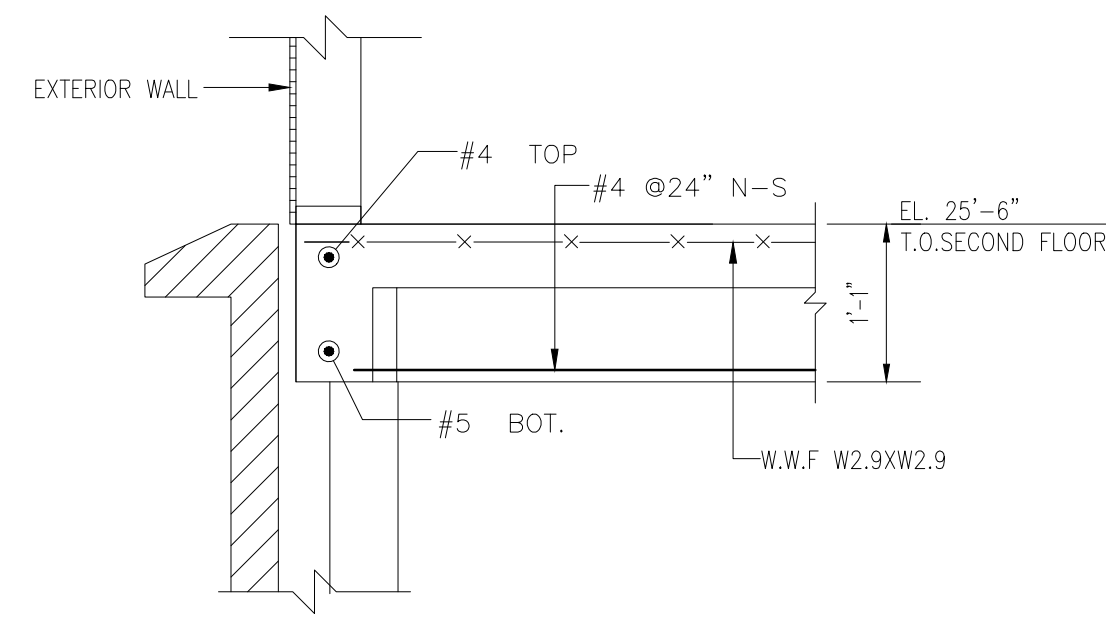

SECTION 3
SCALE - 3/4"=1'-0"
REF:2B/SD2.0

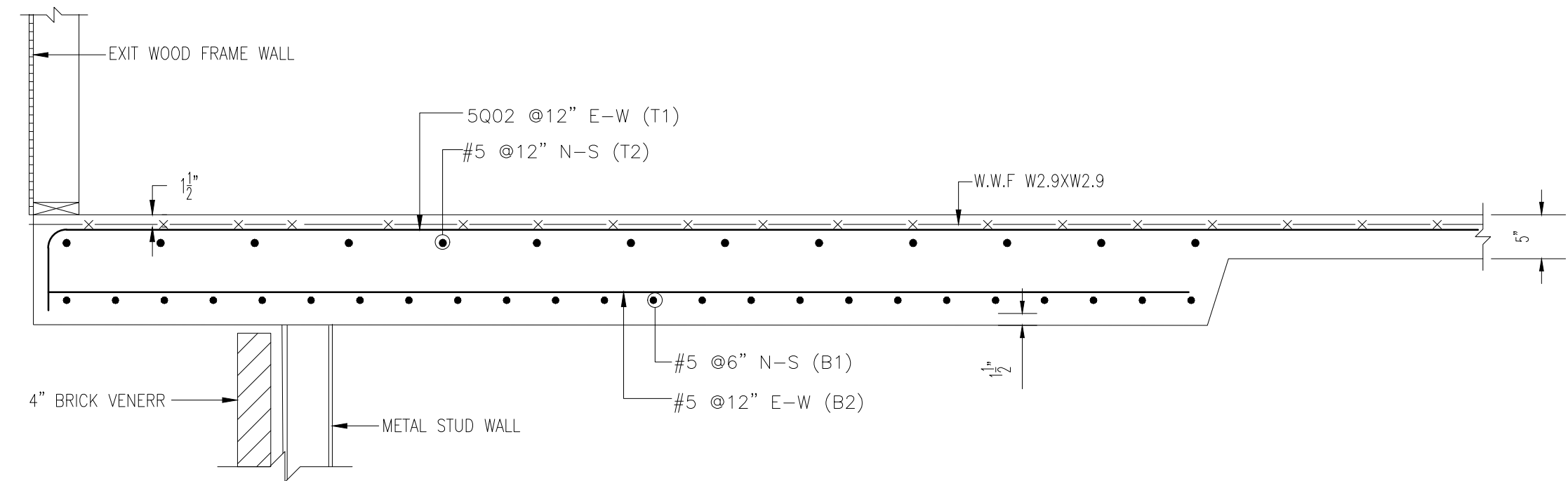

SECTION 4
SCALE - 3/4"=1'-0"
REF:1A/SD2.0

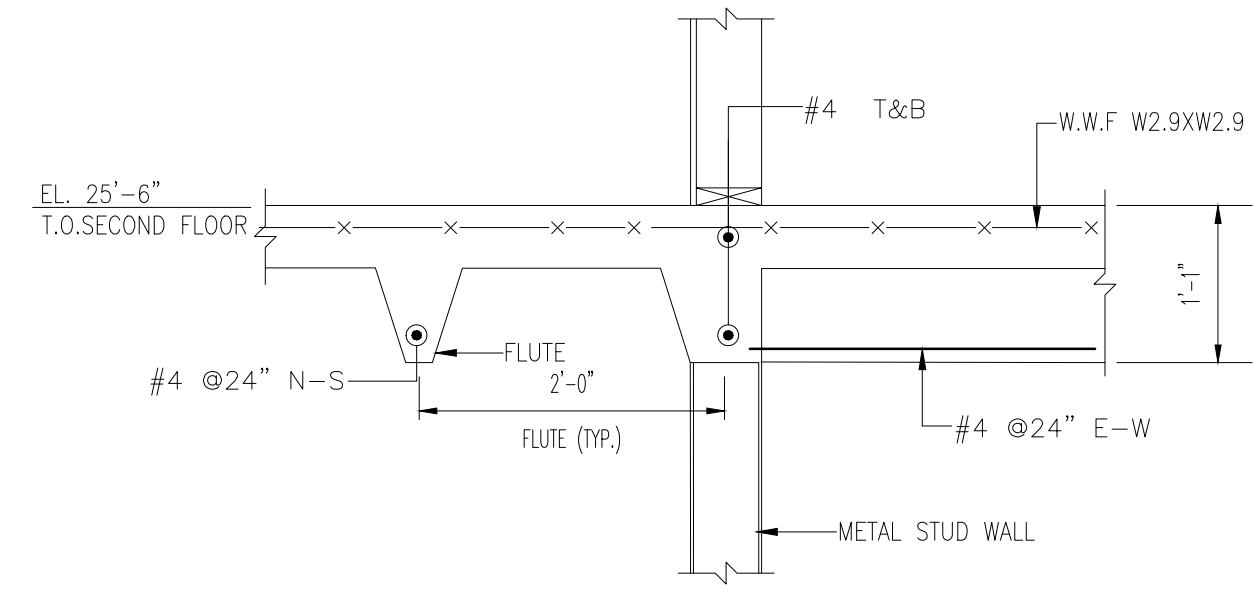

SECTION 5
SCALE - 3/4"=1'-0"
REF:7/SD2.0

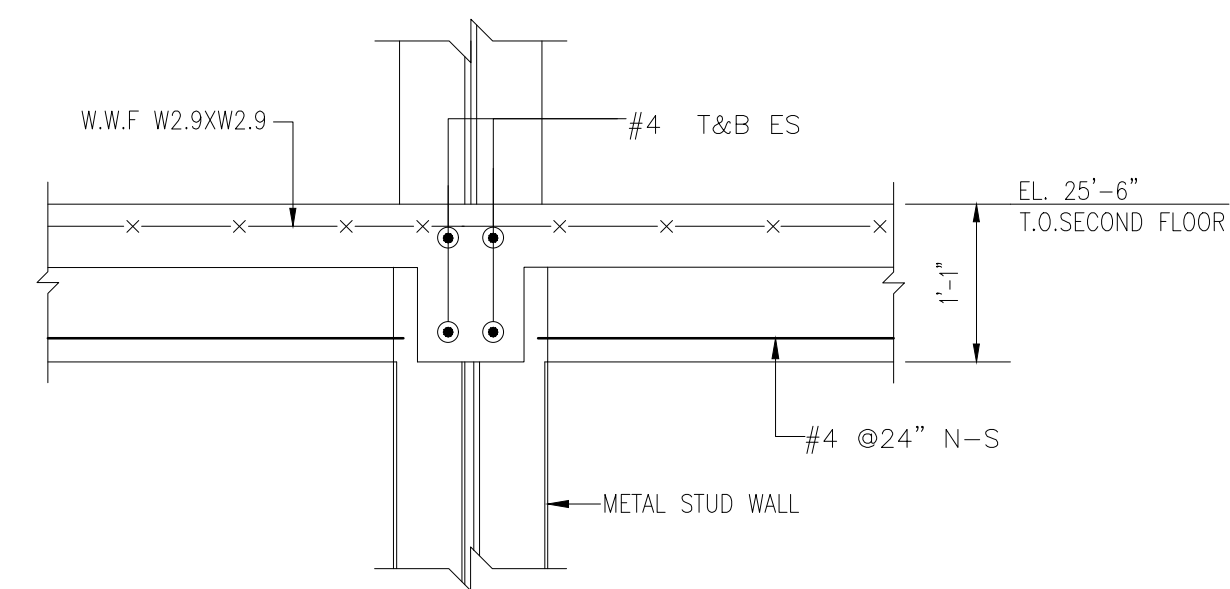

SECTION 6
SCALE - 3/4"=1'-0"
REF:3/SD2.0

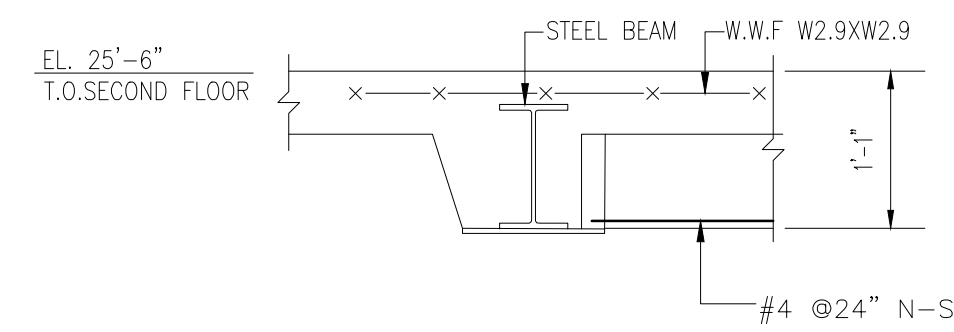

SECTION 7
SCALE - 3/4"=1'-0"
REF:17/SD2.0

Release Number: 873 TO 875 BMR LIST

Bar Mark	Qty	Size	Total Length	Type	'0	'6	'0	'6	'0	'6	'0	'6	'0	'6
Varies To														
0401a	1	#4	3'-5"											
0401n	1	#4	11'-10"											
0402a	1	#4	2'-5"											
Varies To														
0402h	1	#4	14'-5"											
0403a	1	#4	5'-8"											
Varies To														
0403g	1	#4	8'-3"											
0404a	1	#4	3'-8"											
Varies To														
0404g	1	#4	15'-5"											
0405a	1	#4	3'-10"											
Varies To														
0405g	1	#4	15'-6"											
0406a	1	#4	2'-2"											
Varies To														
0406h	1	#4	14'-2"											
0407a	1	#4	3'-0"											
Varies To														
0407i	1	#4	23'-5"											
0408a	1	#4	0'-11"											
Varies To														
0408d	1	#4	2'-0"											
0409a	1	#4	1'-0"											
Varies To														
0409d	1	#4	2'-0"											
0410a	1	#4	3'-0"											
Varies To														
0410f	1	#4	23'-6"											
0411a	1	#4	5'-6"											
Varies To														
0411e	1	#4	7'-5"											
4001	42	#4	4'-2"	17										
4002	4	#4	4'-1"	3										
4003	2	#4	4'-1"	3										
4004	4	#4	4'-1"	3										
4005	2	#4	5'-5"	3										
5001	14	#5	11'-5"	2	0'-10"									
5002	26	#5	15'-2"	2	0'-10"									
5003	2	#5	5'-1"	3										
5004	34	#5	14'-6"	2	0'-10"									
5005	25	#5	14'-7"	2	0'-10"									

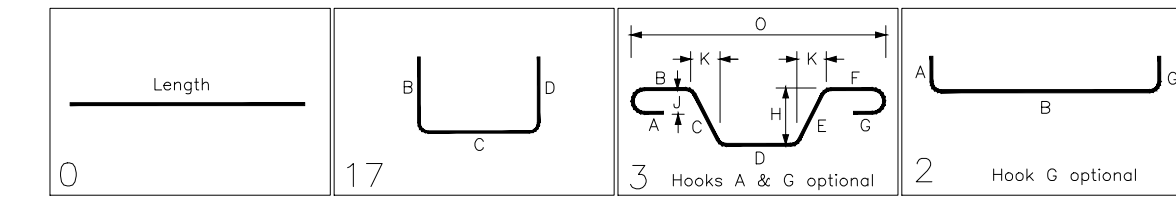

ALL BARS IN THIS DRAWING
ASTM A615 GRADE 60
BLACK UNCOATED

LAP SCHEDULE

SIZE	4000 PSI	
	TOP	OTHERS
#3	24"	19"
#4	32"	25"
#5	40"	31"
#6	48"	37"
#7	70"	54"
#8	80"	62"
#9	91"	70"
#10	102"	79"
#11	113"	87"

ABBREVIATIONS

STIRRUP	STIRR.
TOP & BOTTOM	T&B
TOP OF SLAB	T.O.S
NORTH-SOUTH	N-S
EAST-WEST	E-W

SAMPLE